

Telescopic buttstock with folding adapter CRC 9033

! WARNING

First of all, make sure that the weapon is unloaded, the chamber is empty and sufficient level of safety is provided.

Read the instructions carefully before installing. With careless handling, spring-loaded parts can pop out with enough strength to cause injury.

Remember that careless handling of the weapon can lead to injury or death.

KPYK Industries LLC is not liable for injury, death or damage to property that arose due to incorrect installation, unauthorized modification or unlawful use of this product.

Thank you for purchasing our product. Rest assured that we have made every effort to make this project the best in the class and make happy all its owners.

All loaded parts of the buttstock are milled from whole aluminum plates of various series. This allows us to talk about a large margin of safety when used even in extreme conditions.

INSTALLING

STEP 1

First of all, make sure that the weapon is unloaded, the chamber is empty and sufficient level of safety is provided.

Read the instructions carefully before installing. With careless handling, spring-loaded parts can pop out with enough strength to cause injury.

Remember that careless handling of the weapon can lead to injury or death.

KPYK Industries LLC is not liable for injury, death or damage to property that arose due to incorrect installation, unauthorized modification or unlawful use of this product.

STEP 2

Uninstall the old buttstock.

STEP 3

Insert the wedge clamp into the front of the adapter base.

PICTURE 1

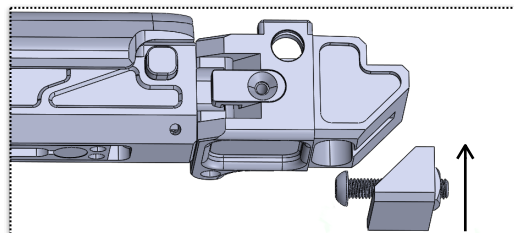

STEP 4

Insert the buttstock with the adapter into the receiver, and tighten the two upper locking screws. Long in front, short closer to the butt.

PICTURE 2

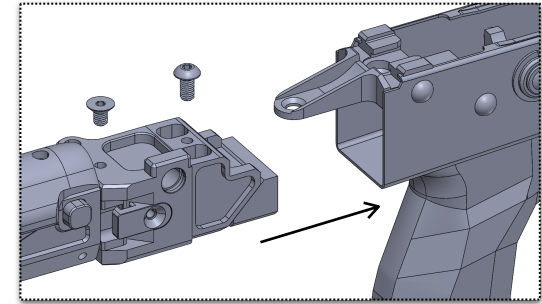

STEP 5

Fold the buttstock and tighten the wedge adjusting screw through the hole.

PICTURE 3

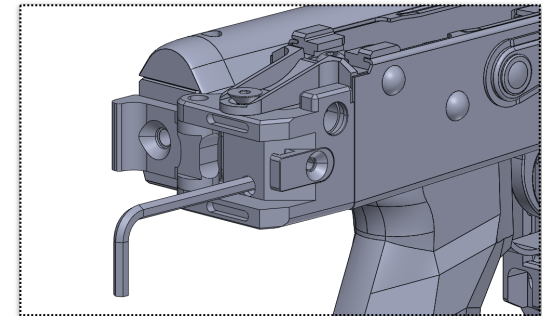

STEP 6

Set the buttplate at a height convenient for you.

PICTURE 4

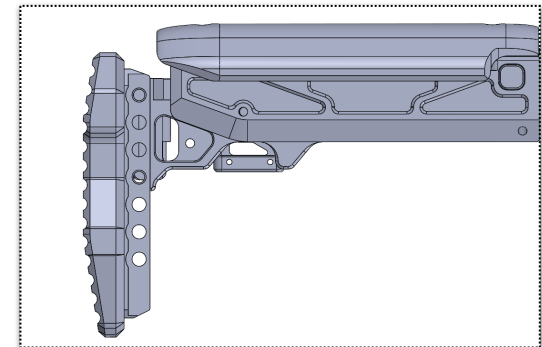

STEP 7

FIXATION IN FOLDED POSITION

Fixing of buttstock in the folded position is possible in two ways.

Method 1. Using a magnetic block.

To do this, fold the buttstock to the contact of the magnetic block with the receiver.

PICTURE 5

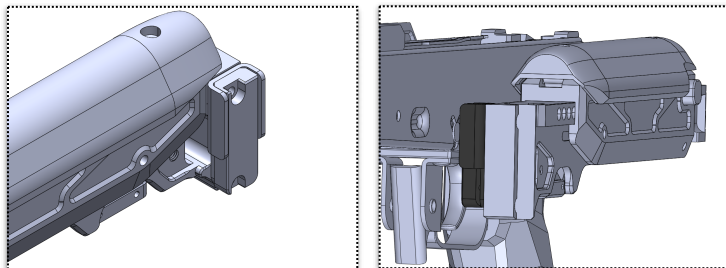

Method 2. Using a spring clip.

Fasten the spring clip to the buttstock at the height required for locking in the folded position.

PICTURE 6

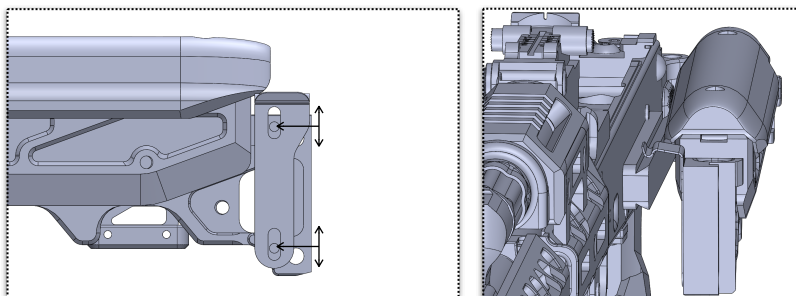

PRODUCT FEATURES and TECHNICAL DATA

- ✓ Weight – 510 gr.
- ✓ Length – from 17.5 cm. till 22 cm.
- ✓ Maximum lift of the cheekrest – 2 cm.
- ✓ Number of cheekrest position – 4.
- ✓ Height adjustment of the buttplate +/- 3 cm.
- ✓ Has regular places for fastening of a belt on a sling and on QD.
- ✓ In all loaded threads we use special stainless steel inserts that increase the possible tightening force of the screws and increase the service life of the thread itself
- ✓ 90 % of all loaded parts are milled from whole aluminum plates of various series.
- ✓ Manufacturing method – milling
- ✓ For maximum surface protection, we are using two-component ceramic CERAKOTE coating

IN THE SET

1. Telescopic buttstock CRC 5002 – 1 pc.
2. Folding adapter CRC 9033 – 1 pc.
3. QD flush cup – 1 pc.
4. Screws and wrenches kit – 1 pc.
5. Spring clip – 1 pc.



WARNING

For the reliability of the mounting, we recommend greasing the screws by threadlocker with medium bond strength.

WARRANTY and SERVICE LIFE



Service life – unlimited.

12 month warranty. This means that in case of detecting a manufacturing defect during the 12 month, such a product will be replaced with a new analogue or KPYK Industries LLC. (or an authorized representative) make a free repair.

northern-raven.com



Facebook



KPYK Industries LLC
12 Antona Tsedika st., Kyiv 03057, Ukraine
www.northern-raven.com,
inbox@crook.com.ua
All rights reserved